



# Poppin' Presentations

Snack on popcorn as students present book summaries, science fair projects, all-about-me displays, poetry readings, and more!



**Interactive** • **Portable** • **Reusable**

See reverse for instructions



This creative activity sheet is a gift from your TREND Retailer!

# Here's how to make it!

## Use these TREND products:

- T-30100 Presentation Board (24" x 46")
- T-30200 Presentation Board Header
- T-4002 Multicolor Wipe-Off® Sentence Strips
- T-10962 Popcorn Classic Accents® Variety Pack
- T-10073 Popcorn Box Classic Accents®
- T-80025 Popcorn Discovery Trimmer®
- T-98003 Wipe-Off® Markers

## You'll also need:

- $\frac{1}{2}$ " x 36" wooden dowel
- White paper roll (18" x 200')
- Hook-n-loop tape
- Double-stick tape
- Masking tape
- 2" large binder clips
- 1" medium binder clips
- Fadeless paper
- Ruler
- Sharp cutting tool, or razor blade
- Markers and/or crayons

## Detail of story frames

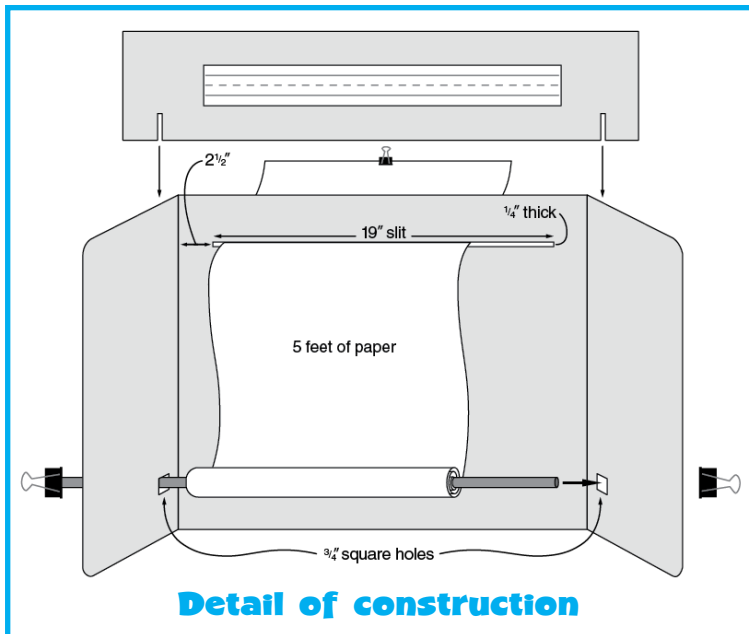

## Assembly directions:

1. Measure from the top of the presentation board to the center, 4 inches and mark a dot. Cut a  $\frac{1}{4}$ " x 19" slit. Leave  $2\frac{1}{2}$ " of space on either side of the slit.
2. On side panels, measure 4" from the bottom of the board and 1" in from the crease. Cut a  $\frac{3}{4}$ " square hole.
3. Decorate as shown.
4. Tape 5 feet of the paper roll to the dowel. Using a pencil and a ruler, divide the paper into 10" frames. Be sure to leave 2" of blank space between each frame. Students may color their illustrations within each 10" frame.
5. Insert the dowel into each square hole. Feed the top of the paper through the slit. Weigh down the paper with a medium-size binder clip. Secure each end of the dowel with a large binder clip.
6. Attach the Wipe-Off® Sentence Strip to the center of the presentation board header using double-stick tape. Students may then use a Wipe-Off® marker to write the name of their presentation.
7. Use hook-n-loop tape to adhere important information to each panel.

This creative activity sheet is a gift from your TREND Retailer!